

Flat Area Sensor With Plastic Case

■ Features

- 13mm slim body with fresnel lens
- Adoption of plastic (PC/ABS) injection case
- Various functions; stop transmission, interference prevention, lightening/flashing JOB indicator, Light ON/Dark ON operation by switch
- Easy to recognize at side, front, and long-distance by high brightness LED of Emitter and Receiver
- Fast response time up to 7ms
- 4 models with various optical axes (8 to 20EA) and sensing height (140 to 380mm)
- Protection structure IP40 (IEC standard)



⚠ Please read "Caution for your safety" in operation manual before using.



■ Specifications

Model	NPN open collector output	BWP20-08	BWP20-12	BWP20-16	BWP20-20
	PNP open collector output	BWP20-08P	BWP20-12P	BWP20-16P	BWP20-20P
Sensing type	Through-beam				
Sensing distance	0.1 to 5m				
Sensing target	Opaque materials of min.Ø30mm				
Optical axis pitch	20mm				
Number of optical axis	8EA	12EA	16EA	20EA	
Sensing width	140mm	220mm	300mm	380mm	
Power supply	12-24VDC ±10% (Ripple P-P : Max. 10%)				
Protection circuit	Built-in				
Current consumption	Emitter : Max. 80mA, Receiver : Max. 80mA				
Control output	NPN or PNP open collector output • Load voltage : Max. 30VDC • Load current : Max. 150mA • Residual voltage - NPN : Max. 1V, PNP : Min. 2.5V				
Operation mode	Light ON/Dark ON by switch				
Short-circuit protection	Built-in				
Response time	Max. 6ms (Frequency B selection is max. 7ms)				
Light source	Infrared LED (850nm modulated)				
Synchronization type	Synchronized by synchronous line				
Interference protection	Interference protection by transmission frequency selection				
Environment	Ambient illumination	Sunlight : Max. 10,000lx (received light side illumination)			
	Ambient temperature	-10 to 55°C, storage : -20 to 60°C			
	Ambient humidity	35 to 85%RH, storage : 35 to 85%RH			
Noise resistance	±240V the square wave noise (pulse width: 1μs) by the noise simulation				
Dielectric strength	1,000VAC 50/60Hz for 1 minute				
Insulation resistance	Min. 20MΩ (at 500VDC megger)				
Vibration	1.5mm amplitude or 300m/s ² at frequency of 10 to 55Hz (for 1 min.) in each X, Y, Z direction for 2 hours				
Shock	500m/s ² (approx. 50G) in each X, Y, Z direction for 3 times				
Protection structure	IP40 (IEC standard)				
Material	Case : PC/ABS, Sensing part : PMMA				
Cable	Ø3.5mm, 4-wire, Length : 3m (Emitter: Ø3.5mm, 4-wire, Length : 3m) (AWG 24, Core diameter : 0.08mm, Number of cores : 40, Insulator out diameter : Ø1mm)				
Approval	CE				
Weight ^{*1}	Approx. 400g (approx. 280g)	Approx. 520g (approx. 320g)	Approx. 620g (approx. 360g)	Approx. 680g (approx. 430g)	

※1: The weight includes packaging. The weight in parentheses is for unit only.

※ The temperature or humidity mentioned in Environment indicates a non freezing or condensation environment.

(A) Photoelectric Sensors

(B) Fiber Optic Sensors

(C) Door/Area Sensors

(D) Proximity Sensors

(E) Pressure Sensors

(F) Rotary Encoders

(G) Connectors/ Sockets

(H) Temperature Controllers

(I) SSRs / Power Controllers

(J) Counters

(K) Timers

(L) Panel Meters

(M) Tacho / Speed / Pulse Meters

(N) Display Units

(O) Sensor Controllers

(P) Switching Mode Power Supplies

(Q) Stepper Motors & Drivers & Controllers

(R) Graphic/ Logic Panels

(S) Field Network Devices

(T) Software

Feature Data

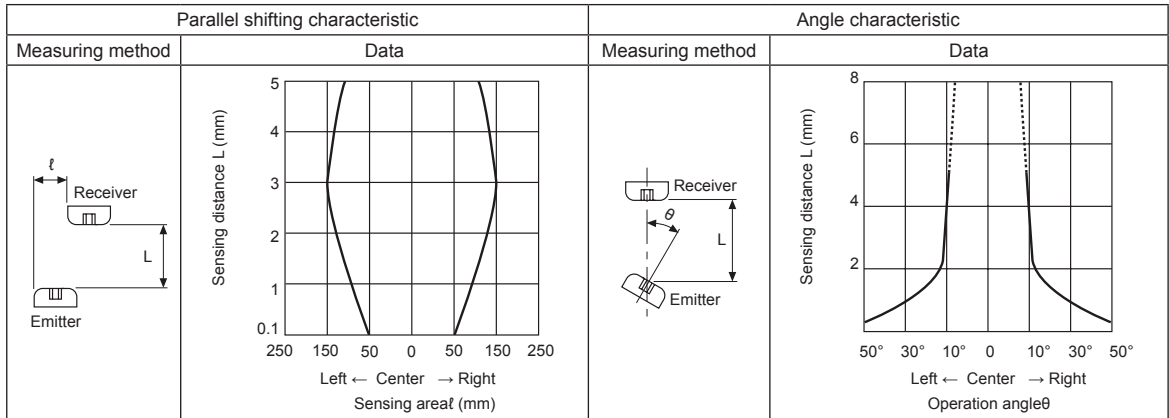

Input/Output Circuit And Connection Diagram

• NPN open collector output

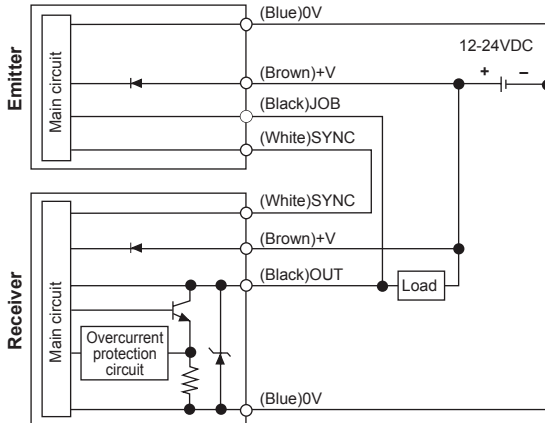

• PNP open collector output

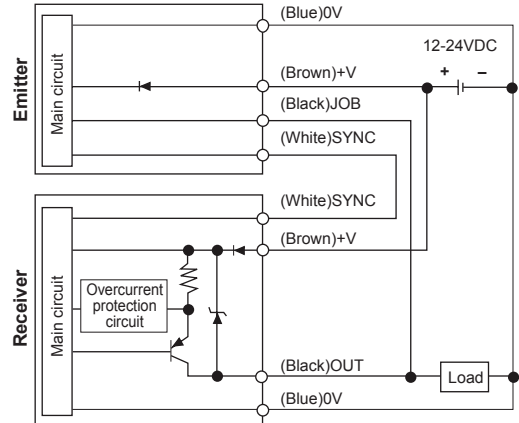

※If the receiver OUT (black) line and the emitter JOB (black) line are not connected each other, the JOB indicator of the emitter is not operated and maintain the light status.

Operation Timing Diagram

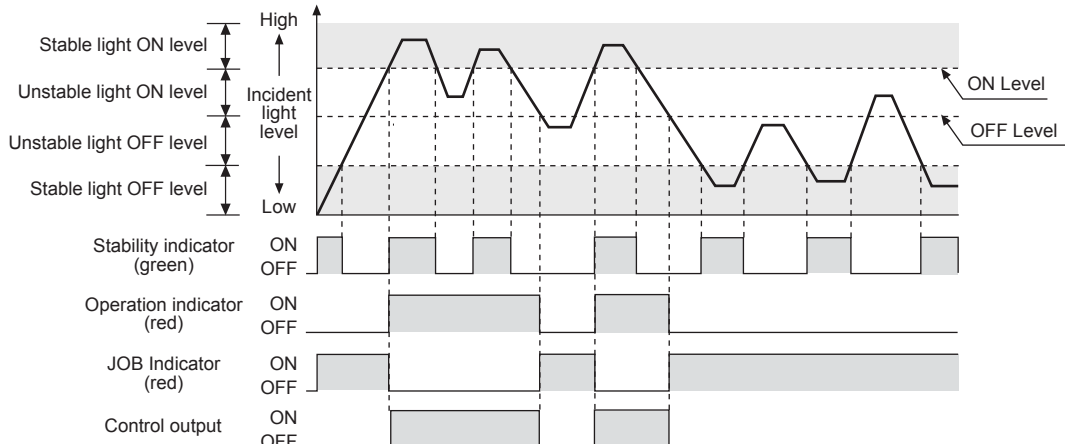

※The waveforms of operation indicator, job indicator, and control output are the state of operation for Light ON, but in case of Dark ON, it is opposite operation against Light ON mode.

(A) Photoelectric Sensors

(B) Fiber Optic Sensors

(C) Door/Area Sensors

(D) Proximity Sensors

(E) Pressure Sensors

(F) Rotary Encoders

(G) Connectors/Sockets

(H) Temperature Controllers

(I) SSRs / Power Controllers

(J) Counters

(K) Timers

(L) Panel Meters

(M) Tacho / Speed / Pulse Meters

(N) Display Units

(O) Sensor Controllers

(P) Switching Mode Power Supplies

(Q) Stepper Motors & Drivers & Controllers

(R) Graphic/Logic Panels

(S) Field Network Devices

(T) Software

BWP Series

■ Structure

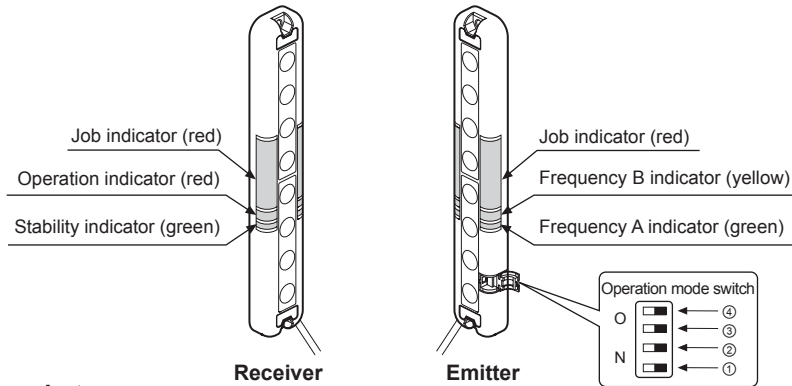

◎ Mounting of bracket

No	Function	Switch OFF	Switch ON
①	Transmission frequency selection	Frequency A	Frequency B
②	Light ON/Dark ON selection	Light ON operation	Dark ON operation
③	Steady/flashing light of Job indicator selection	Job indicator with Steady light	Job indicator with Flashing light
④	Job/TEST selection	Normal mode	TEST mode

■ Functions

◎ TEST (stop transmission)

When selecting TEST mode, emit is stopped and green & yellow LED of emitter flashes. It is available to check whether sensor operates properly with stopping the transmission in TEST mode. It is changed to light OFF status when emit the transmission is stopped, control output is OFF in Light ON mode and ON in Dark ON mode.

● Control output pulse for TEST input

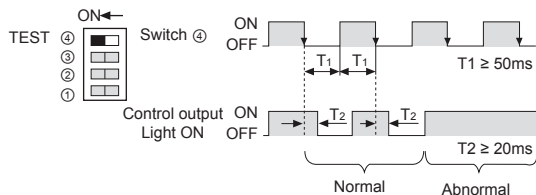

◎ Light-ON / Dark-ON operation mode

The control output is ON when it is light ON in Light ON and the control output is ON when it is light OFF in Dark ON. It is available to select with user's preference.

	Operation mode switch	Control output operation
Light ON		It is ON when it is light ON.
Dark ON		It is ON when it is light OFF.

◎ Interference prevention

In case of using 2pcs of sensor in serial or parallel in order to extend sensing width, it may cause sensing error because of light interference.

This function is operating a sensor in transmission frequency A and another sensor in transmission frequency B to avoid these sensing errors by the light interference.

	Operation mode switch	Frequency A, B indicator
Sensor ㉑ (Transmission frequency A)		
Sensor ㉒ (Transmission frequency B)		

◎ Lightening/Flashing JOB indicator

JOB indicator will be lighted and flashed to make out work sensing operation more easily.

Operation mode switch	JOB indicator operation
	Lighting indicator
	Flashing indicator

■ Installation

◎ For direction of installation

Emitter and receiver should be installed as same up/down position.

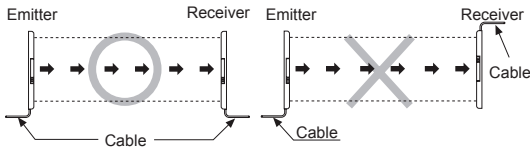

◎ For reflection from the surface of wall and flat

When installing it as below the light reflected from the surface of wall and flat will not be shaded. Please, check whether it operates normally or not with a sensing target before using. (Interval distance : Min. 0.3m)

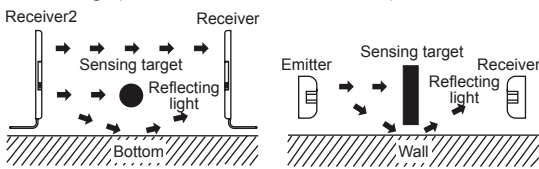

◎ For prevention of interference

It may cause interference when installing more than 2 sets of the sensor. In order to avoid the interference of the sensor, please install as following figures and use the interference protection function.

● Transmission direction should be opposite between 2 sets

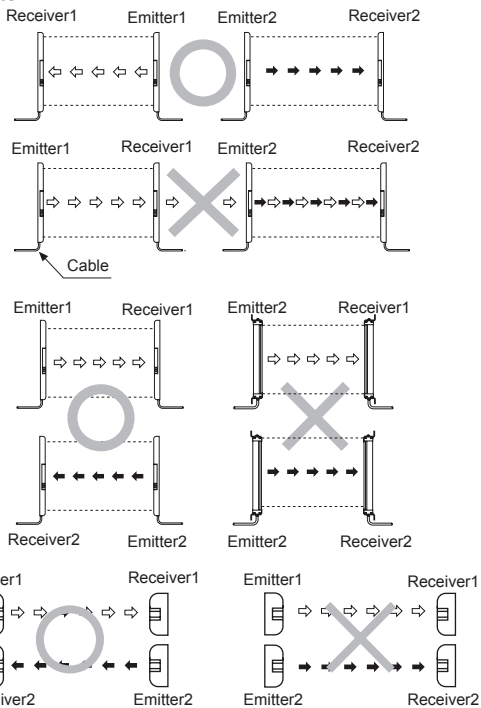

● Baffle should be installed between 2 sets.

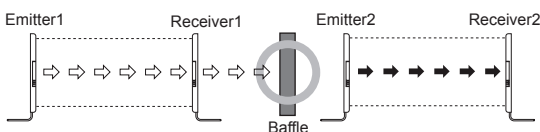

● It should be installed out of the interference distance

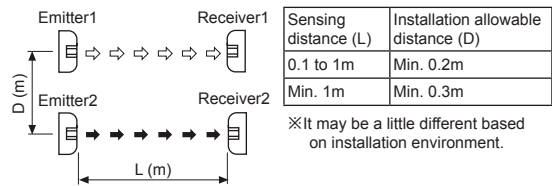

■ Operation Indicator

Item	Emitter			Receiver			Control output
	Indicator	Indicator	JOB Indicator	Indicator	Indicator	JOB Indicator	
Power on	☀	●	—	—	—	—	—
FREQ. A operation	☀	●	—	—	—	—	—
FREQ. B operation	☀	☀	—	—	—	—	—
TEST	▶	◀	☀	☀	●	☀	OFF
Stable light ON	—	—	●	☀	●	●	ON
Unstable light ON	—	—	●	☀	●	●	ON
Unstable light OFF	—	—	☀	●	●	☀	OFF
Stable light OFF	—	—	☀	☀	●	☀	OFF
Flashing function ON	—	—	◐	☀	●	◐	OFF
Synchronous line malfunction	—	—	☀	▶	◀	☀	OFF
Overcurrent	—	—	☀	◐	◐	☀	OFF

Display classification list

☀	Light ON
●	Light OFF
◐	Flashing by 0.3 sec.
◐ ◐	Flashing simultaneously by 0.3 sec.
▶ ◐	Cross-Flashing by 0.3 sec.

※The operation of 'Operation indicator (Red)', 'Job indicator (Red)', 'Control output' is for Light ON, in case of Dark ON, it is opposite operation against Light ON. (In case, malfunction of synchronous line and over current, control output is OFF regardless of the mode.)

■ Troubleshooting

Malfunction	Cause	Troubleshooting
Non-operation	Power supply	Supply rated power.
	Cable incorrect connection or disconnection	Check the wiring.
	Rated connection failure	Use it within rated sensing distance.
Non-operation in sometimes	Pollution by dirt of sensor cover	Remove dirt by soft brush or cloth.
	Connector connection failure	Check the assembled part of the connector.
Control output is OFF even though there is not a target object.	Out of rated sensing distance	Use within rated sensing distance.
	There is an obstacle to cut off the light emitted between emitter and receiver	Remove the obstacle.
LED displays for synchronous line malfunction	There is a strong electric wave or noise generated by motor, electric generator, high voltage line etc.	Put away the strong electric wave or noise generator.
	Synchronous line incorrect connection or disconnection	Check the wiring.
LED displays for over current	Break of synchronous circuit of emitter or receiver	Contact our company.
	Control output line is shorten	Check the wiring.
	Over load	Check the rated load capacity.

(A) Photoelectric Sensors

(B) Fiber Optic Sensors

(C) Door/Area Sensors

(D) Proximity Sensors

(E) Pressure Sensors

(F) Rotary Encoders

(G) Connectors/ Sockets

(H) Temperature Controllers

(I) SSRs / Power Controllers

(J) Counters

(K) Timers

(L) Panel Meters

(M) Tacho / Speed / Pulse Meters

(N) Display Units

(O) Sensor Controllers

(P) Switching Mode Power Supplies

(Q) Stepper Motors & Controllers

(R) Graphic/ Logic Panels

(S) Field Network Devices

(T) Software