

Autonics 2-Phase Closed-Loop Stepper Motor Ai-M SERIES INSTRUCTION MANUAL



Thank you for choosing our Autonics product. Please read the following safety considerations before use.

Safety Considerations

- ⊠ Please observe all safety considerations for safe and proper product operation to avoid hazards.
- ⚠ symbol represents caution due to special circumstances in which hazards may occur.

Warning Failure to follow these instructions may result in serious injury or death.
Caution Failure to follow these instructions may result in personal injury or product damage.

Warning

- Fail-safe device must be installed when using the unit with machinery that may cause serious injury or substantial economic loss.** (e.g. nuclear power control, medical equipment, ships, vehicles, railways, aircraft, combustion apparatus, safety equipment, crime/disaster prevention devices, etc.)
Failure to follow this instruction may result in fire, personal injury, or economic loss.
- Fix the unit on the metal plate.**
Failure to follow this instruction may result in personal injury, or product and ambient equipment damage.
- Do not connect, repair, or inspect the unit while connected to a power source.**
Failure to follow this instruction may result in fire.
- Install the unit after considering counter plan against power failure.**
Failure to follow this instruction may result in personal injury, or economic loss.
- Check 'Connections' before wiring.**
Failure to follow this instruction may result in fire.
- Do not disassemble or modify the unit.**
Failure to follow this instruction may result in fire.
- Install the motor in the housing or ground it.**
Failure to follow this instruction may result in fire, or personal injury.
- Make sure to install covers on motor rotating components.**
Failure to follow this instruction may result in personal injury.
- Do not touch the unit during or after operation for a while.**
Failure to follow this instruction may result in burn due to high temperature of the surface.
- Turn OFF the power directly when error occurs.**
Failure to follow this instruction may result in fire, or personal injury.

Caution

- Use the unit within the rated specifications.**
Failure to follow this instruction may result in fire or product damage.
- Use dry cloth to clean the unit, and do not use water or organic solvent.**
Failure to follow this instruction may result in fire.
- Do not use the unit in the place where flammable/explosive/corrosive gas, humidity, direct sunlight, radiant heat, vibration, impact, or salinity may be present.**
Failure to follow this instruction may result in fire or explosion.
- The motor may overheat depending on the environment.**
Install the unit at the well-ventilated environment and forced cooling with a cooling fan.
Failure to follow this instruction may result in product damage and degradation.

Ordering Information

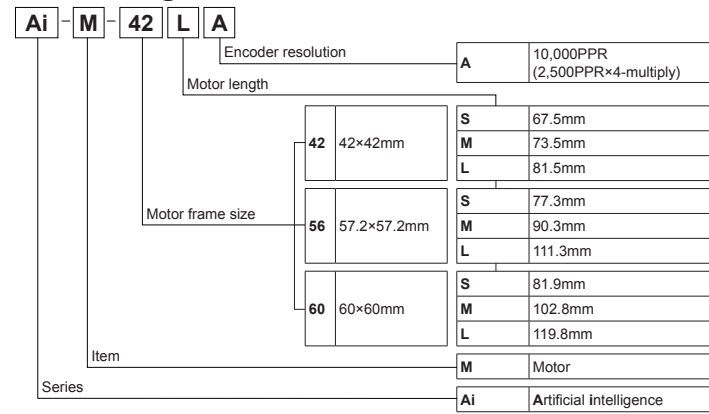

AIS Series			AiC Series		
Set	Driver	Motor	Set	Driver	Motor
AIS-42SA	AIS-D-42SA	Ai-M-42SA	AiC-42SA	AiC-D-42SA	Ai-M-42SA
AIS-42MA	AIS-D-42MA	Ai-M-42MA	AiC-42MA	AiC-D-42MA	Ai-M-42MA
AIS-42LA	AIS-D-42LA	Ai-M-42LA	AiC-42LA	AiC-D-42LA	Ai-M-42LA
AIS-56SA	AIS-D-56SA	Ai-M-56SA	AiC-56SA	AiC-D-56SA	Ai-M-56SA
AIS-56MA	AIS-D-56MA	Ai-M-56MA	AiC-56MA	AiC-D-56MA	Ai-M-56MA
AIS-56LA	AIS-D-56LA	Ai-M-56LA	AiC-56LA	AiC-D-56LA	Ai-M-56LA
AIS-60SA	AIS-D-60SA	Ai-M-60SA	AiC-60SA	AiC-D-60SA	Ai-M-60SA
AIS-60MA	AIS-D-60MA	Ai-M-60MA	AiC-60MA	AiC-D-60MA	Ai-M-60MA
AIS-60LA	AIS-D-60LA	Ai-M-60LA	AiC-60LA	AiC-D-60LA	Ai-M-60LA

Encoder Control Output Diagram

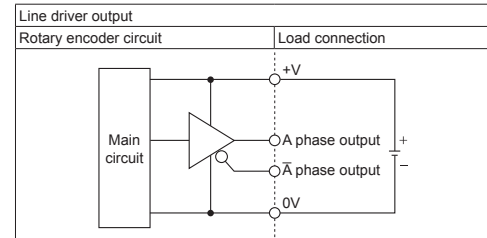

- All output circuits of A, A-bar, B, B-bar, Z, Z-bar phase are the same.
- The above specifications are subject to change and some models may be discontinued without notice.
- Be sure to follow cautions written in the instruction manual and the technical descriptions (catalog, homepage).

Specifications

Motor

Frame size 42mm

Model	Ai-M-42SA	Ai-M-42MA	Ai-M-42LA
Max. holding torque*1	2.55kgf·cm (0.25N·m)	4.08kgf·cm (0.4N·m)	4.89kgf·cm (0.48N·m)
Rotor moment of inertia	35g·cm ² (35×10 ⁻⁷ kg·m ²)	54g·cm ² (54×10 ⁻⁷ kg·m ²)	77g·cm ² (77×10 ⁻⁷ kg·m ²)
Rated current	1.7A/Phase		
Resistance	1.7Ω/Phase ±10%	1.85Ω/Phase ±10%	2.1Ω/Phase ±10%
Inductance	1.9mH/Phase ±20%	3.5mH/Phase ±20%	4.4mH/Phase ±20%
Weight*2	Approx. 0.45kg (approx. 0.34kg)	Approx. 0.52kg (approx. 0.41kg)	Approx. 0.59kg (approx. 0.48kg)

Frame size 56mm

Model	Ai-M-56SA	Ai-M-56MA	Ai-M-56LA
Max. holding torque*1	6.12kgf·cm (0.6N·m)	12.24kgf·cm (1.2N·m)	20.39kgf·cm (2.0N·m)
Rotor moment of inertia	140g·cm ² (140×10 ⁻⁷ kg·m ²)	280g·cm ² (280×10 ⁻⁷ kg·m ²)	480g·cm ² (480×10 ⁻⁷ kg·m ²)
Rated current	3.5A/Phase		
Resistance	0.55Ω/Phase ±10%	0.57Ω/Phase ±10%	0.93Ω/Phase ±10%
Inductance	1.05mH/Phase ±20%	1.8mH/Phase ±20%	3.7mH/Phase ±20%
Weight*2	Approx. 0.76kg (approx. 0.62kg)	Approx. 0.99kg (approx. 0.85kg)	Approx. 1.36kg (approx. 1.22kg)

Frame size 60mm

Model	Ai-M-60SA	Ai-M-60MA	Ai-M-60LA
Max. holding torque*1	11.22kgf·cm (1.1N·m)	22.43kgf·cm (2.2N·m)	29.57kgf·cm (2.9N·m)
Rotor moment of inertia	240g·cm ² (240×10 ⁻⁷ kg·m ²)	490g·cm ² (490×10 ⁻⁷ kg·m ²)	690g·cm ² (690×10 ⁻⁷ kg·m ²)
Rated current	3.5A/Phase		
Resistance	1.0Ω/Phase ±10%	1.23Ω/Phase ±10%	1.3Ω/Phase ±10%
Inductance	1.5mH/Phase ±20%	2.6mH/Phase ±20%	3.8mH/Phase ±20%
Weight*2	Approx. 0.89kg (approx. 0.75kg)	Approx. 1.27kg (approx. 1.13kg)	Approx. 1.58kg (approx. 1.44kg)

*1: Max. holding torque is maintenance torque of stopping the motor when supplying the rated current (2-phase excitation) and is the standard for comparing the performance of motors.
 *2: The weight includes packaging. The weight in parenthesis is for unit only.

Common specifications

Standard step angle	1.8° / 0.9° (Full/Half step)
Motor phase	2 phase
Run method	Bipolar
Insulation class	B type (130°C)
Insulation resistance	Over 100MΩ (at 500VDC megger) between motor coil-case
Dielectric strength	0.5kVAC 50/60Hz for 1 min between motor coil-case
Vibration	1.5mm amplitude at frequency of 10 to 55Hz (for 1 min) in each X, Y, Z direction for 2 hours
Shock	Approx. max. 50G
Environment	Ambient temperature: 0 to 50°C, storage: -20 to 70°C Ambient humidity: 20 to 85%RH, storage: 15 to 90%RH
Approval	CE
Protection structure	IP30 (IEC34-5 standard)
Stop angle error*1	±0.09°
Shaft vibration*2	0.03mm T.I.R.
Radial Movement*3	Max. 0.025mm (load 25N)
Axial Movement*4	Max. 0.01mm (load 50N)
Concentricity for shaft of setup in-low	0.05mm T.I.R.
Perpendicularity of set-up plate shaft	0.075mm T.I.R.

*1: Specifications are for full-step angle, without load. (Values may vary by load size)
 *2: T.I.R. (Total Indicator Reading)
 - Indicates total quantity of dial gauge in case of 1 rotation of measuring part around the reference point.

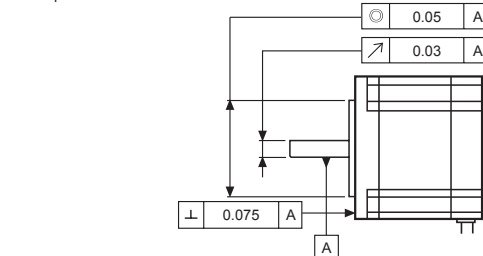

*3: Amount of radial shaft displacement when adding a radial load (25N) to the tip of the motor shaft.
 *4: Amount of axial shaft displacement when adding a axial load (50N) to the shaft.
 *Environment resistance is rated at no freezing or condensation.

Encoder

Item	Incremental rotary encoder
Resolution	10,000PPR (2,500PPR×4-multiply)
Output phase	A, A-bar, B, B-bar, Z, Z-bar
Output duty rate	T/2 ± 1/4 (T=1 cycle of A phase)
Phase difference of output	Output between A and B phase: T/4 ± 1/8 (T=1 cycle of A phase)
Control output	Line driver output
Max. response frequency	300kHz
Power supply	5VDC = ±5% (ripple P-P: max. 5%)
Current consumption	Max. 50mA (disconnection of the load)

Encoder Output Waveforms

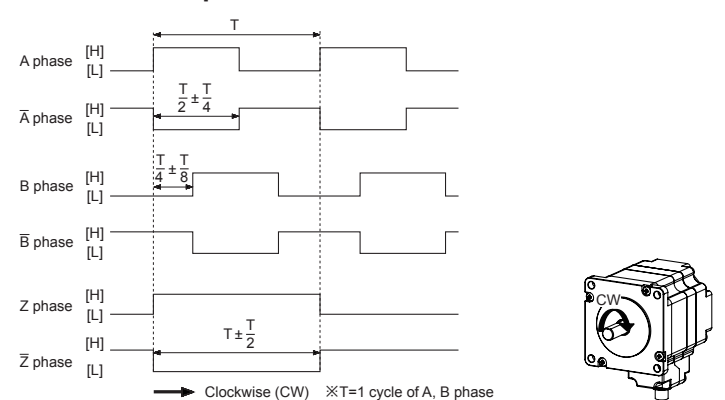

Dimensions

Frame size 42mm

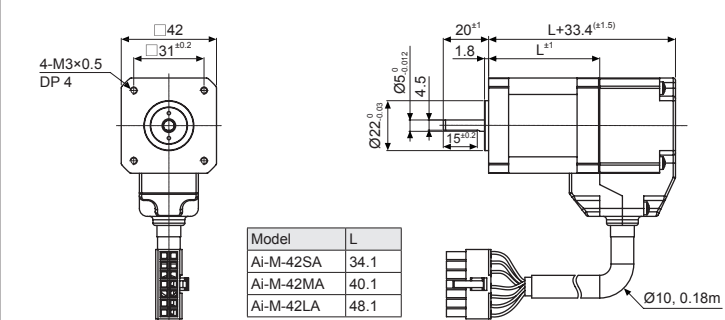

Frame size 56mm

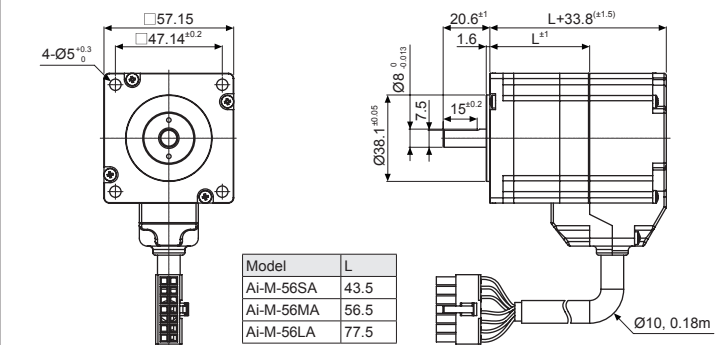

Frame size 60mm

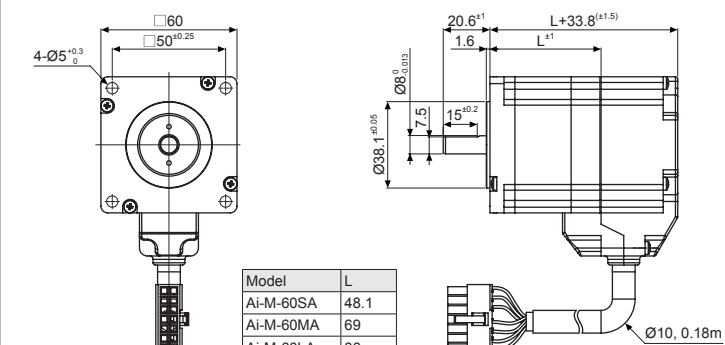

Connection Diagram

Autonics 2 phase closed-loop stepper motors take bipolar wiring methods. The wiring colors for each phase and lead-wire are as the followings:

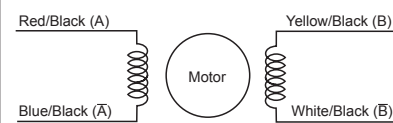

Connection Connectors of Motor

CN2: Motor+Encoder connector				
Pin arrangement	Pin No.	Function	Pin No.	Function
1	GND	8	+5VDC	
2	ENCODER A	9	ENCODER A-bar	
3	ENCODER B	10	ENCODER B-bar	
4	ENCODER Z	11	ENCODER Z-bar	
5	GND EARTH	12	N-C	
6	MOTOR A	13	MOTOR B	
7	MOTOR A-bar	14	MOTOR B-bar	

Type	Specifications	Connector	Connector terminal	Housing	Manufacture
CN2	Motor+Encoder	5557-14R	5556T	—	Molex

*Above connectors are suitable for Ai-M Series. You can use equivalent or substitute connectors.

Cable (sold separately)

Type	Model	Moving
Motor+Encoder cable	Normal	
	C1D14M-C*1	C1DF14M-C*1

*1: □ indicates cable length (1, 2, 3, 5, 7, 10).
 E.g.) C1DF14M-10: 10m moving type motor+encoder cable.

Troubleshooting

- When motor does not rotate**
 - Check the connection status between controller and driver, and pulse input specifications (voltage, width).
 - Check the pulse and direction signal are connected correctly.
- When motor rotates to the opposite direction of the designated direction**
 - When RUN mode is 1-pulse input method, CCW input [H] is for forward, [L] is for backward.
 - When RUN mode is 2-pulse input method, check CW and CCW pulse input are changed or not.
- When motor drive is unstable**
 - Check that driver and motor are connected correctly.
 - Check the driver pulse input specifications (voltage, width).

Motor Installation

1. Mounting direction

Motor can be mounted in any directions-facing up, facing down and side ways. No matter which direction motors to be mounted, make sure not to apply overhung or thrust load on the shaft.
 Refer to the table below for allowable shaft overhung load / thrust load.

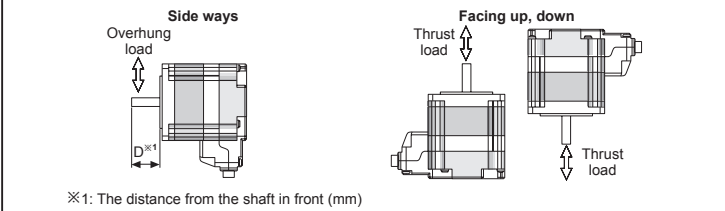

Motor size	The distance from the shaft in front (mm), Allowable overhung load [kgf (N)], Allowable thrust load			
	D=0	D=5	D=10	D=15
Frame size 42mm	2 (20)	2.6 (25)	3.5 (34)	5.3 (52)
Frame size 56mm	5.5 (54)	6.8 (67)	9.1 (89)	13.3 (130)
Frame size 60mm				Under the load of motor

Do not apply excessive force to motor cable when mounting motors. Do not forcibly pull or insert the cable. It may cause poor connection or disconnection of the cable by force. In case of frequent cable movement required application, proper safety countermeasures must be ensured.

2. Mounting method

Frame size 42mm

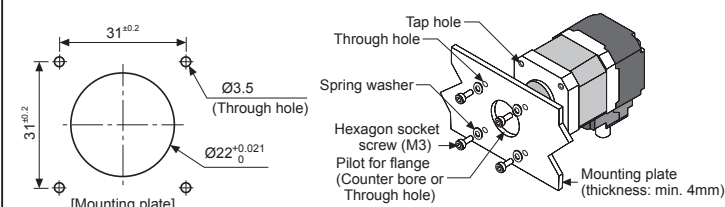

Frame size 56mm/60mm

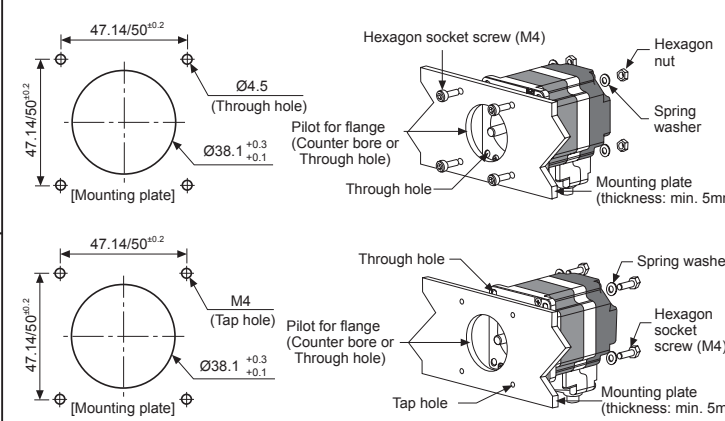

With considering heat radiation and vibration isolation, mount the motor as tight as possible against a metal panel having high thermal conductivity such as iron or aluminum. When mounting motors, use hexagon socket screws, hexagon nuts, spring washers and flat washers. Refer to the table below for allowable thickness of mounting plate and using bolt. Do not draw the wire with over strength 30N after wiring the encoder.

3. Connection with load

When connecting the load, be sure of the center, tension of the belt, and parallel of the pulley. When connecting the load such as a pulley, a belt, be sure of the allowable thrust load, radial load, and shock. Tighten the screw for a coupling or a pulley not to be unscrewed. When connecting a coupling or a pulley on the motor shaft, be sure of damage of the motor shaft and the motor shaft bearing. Do not disassemble or modify the motor shaft to connect with the load.

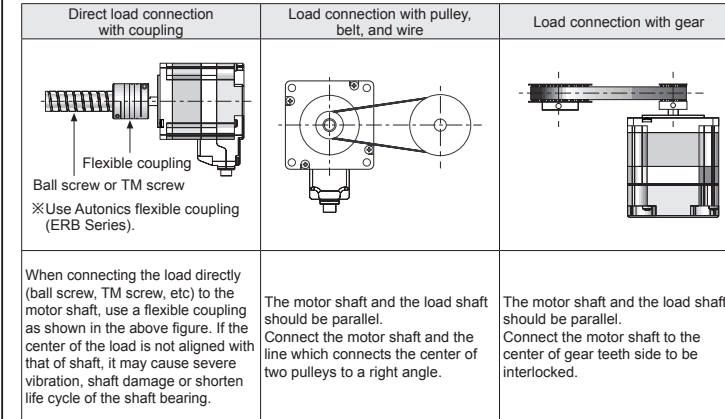

4. Installation condition

- Install the motor in a place that meets certain conditions specified below. It may cause product damage if it is used out of following conditions.
 - Inside of the housing which is installed indoors.
 - (This unit is manufactured for the purpose of attaching to equipment. Install a ventilation device.)
 - Within 0 to 50°C (at non-freezing status) of ambient temperature
 - Within 20 to 85%RH (at non-dew status) of ambient humidity
 - The place without explosive, flammable and corrosive gas
 - The place without direct ray of light
 - The place where dust or metal scrap does not enter into the unit
 - The place without contact with water, oil, or other liquid
 - The place without contact with strong alkali or acidity
 - The place where easy heat dissipation could be made
 - The place without continuous vibration or severe shock
 - The place with less salt content
 - The place with less electronic noise occurs by welding machine, motor, etc.
 - The place where no radioactive substances and magnetic fields exist. It shall be no vacuum status as well.

Motor Characteristics

Frame size 42mm

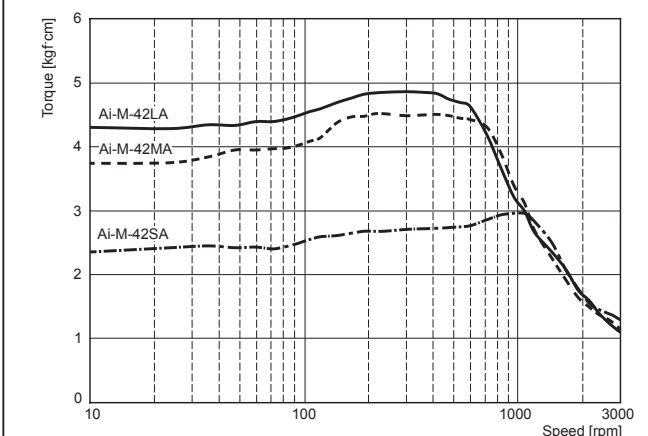

Frame size 56mm

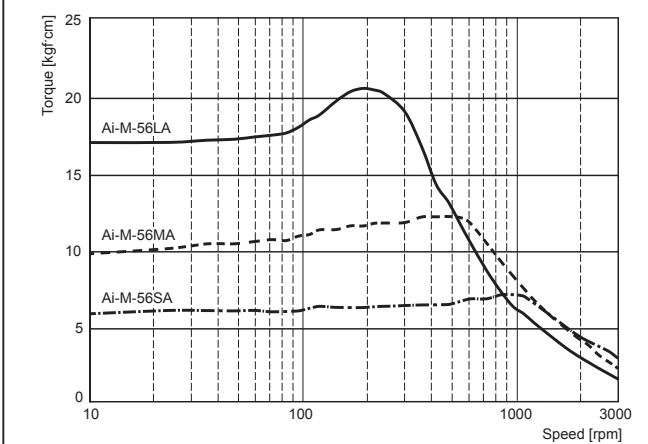

Frame size 60mm

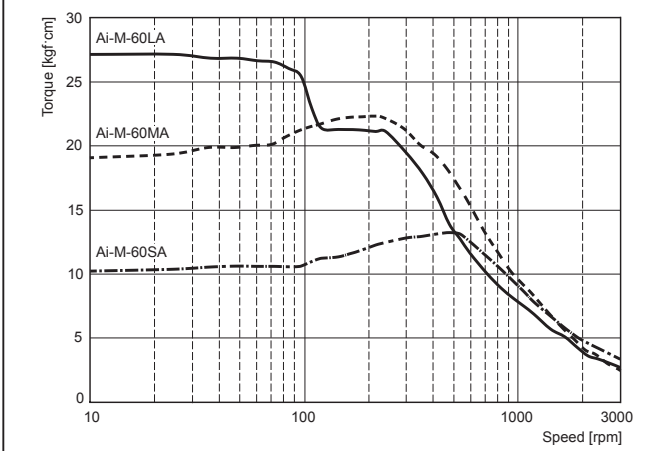

Cautions during Use

- Follow instructions in 'Cautions during Use'. Otherwise, it may cause unexpected accidents.
- Using motors at low temperature may cause reducing ball bearing's grease consistency and friction torque is increased. Start the motor in a steady manner since motor's torque is not to be influenced.
- If wiring encoder cable, separate it from high voltage line or power cable for preventing surge and inductive noise. The cable length should be as short as possible. Failure to follow this instruction may result in raised cable resistance, residual voltage, and output waveform noise
- Must connect the encoder shield cable to the F.G. terminal.
- For using motor, it is recommended to maintenance and inspection regularly.
 - Unwinding bolts and connection parts for the unit installation and load connection
 - Strange sound from ball bearing of the unit
 - Damage and stress of lead cable of the unit
 - Connection error with driver
 - Inconsistency between the axis of motor output and the center, concentric (eccentric, declination) of the load, etc.
- This unit may be used in the following environments.
 - Indoors (in the environment condition rated in 'Specifications')
 - Altitude max. 2,000m
 - Pollution degree 2
 - Installation category II

Major Products

- Photoelectric Sensors
- Fiber Optic Sensors
- Door Sensors
- Door Side Sensors
- Area Sensors
- Proximity Sensors
- Pressure Sensors
- Rotary Encoders
- Connector/Sockets
- Switching Mode Power Supplies
- Control Switches/Lamps/Buzzers
- I/O Terminal Blocks & Cables
- Stepper Motors/Drivers/Motion Controllers
- Graphic/Logic Panels
- Field Network Devices
- Laser Marking System (Fiber, CO₂, Nd: YAG)
- Laser Welding/Cutting System
- Temperature Controllers
- Temperature/Humidity Transducers
- SSRs/Power Controllers
- Counters
- Timers
- Panel Meters
- Tachometer/Pulse (Rate) Meters
- Display Units
- Sensor Controllers

Autonics Corporation
<http://www.autonics.com>
 HEADQUARTERS:
 18, Bansong-ro 513 beon-gil, Haeundae-gu, Busan, South Korea, 48002
 TEL: 82-51-619-3223
 E-mail: sales@autonics.com